

# Infrastructure-less Communication Access Points

NEC Corporation



# Summary of infrastructure-less communication access points

An infrastructure-less communication access point provides a wireless LAN environment for smartphones and other wireless LAN devices without the use of mobile base stations or access points. Its portability allows it to be used anywhere.

## Place anywhere for wide-area communication (MANET-type)

[MANET: Mobile Ad Hoc Networks]

This device has a built-in battery and can be placed anywhere for automatic access to a wide-area communication network. Wireless LAN 1 (for inter-device communication)

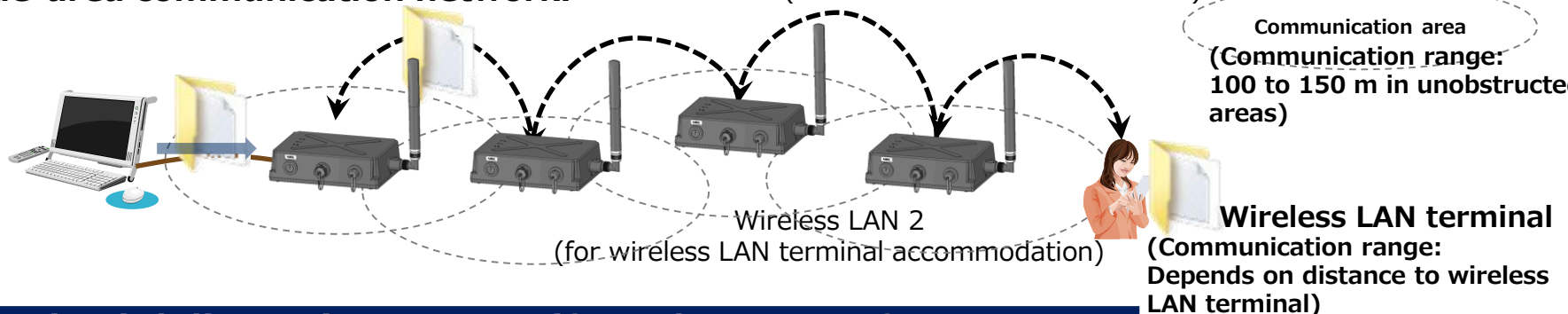

## Promised delivery (DTN-type: if used, some software development is necessary)

[DTN: Delay/Disruption-Tolerant Network]

Promised delivery of internally-stored data even when moving between areas inside and outside the communication range.

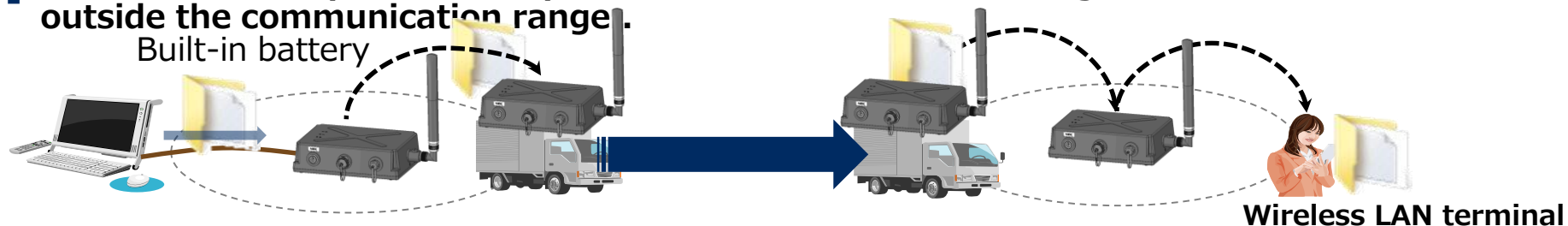

# Video monitoring solution (Expanded range of data collection)

## Value

In areas outside the LTE communication range, on-site personnel have limited ability to check videos. The deployment of ILC-AP expands the range of communication, which contributes to improved work efficiency.

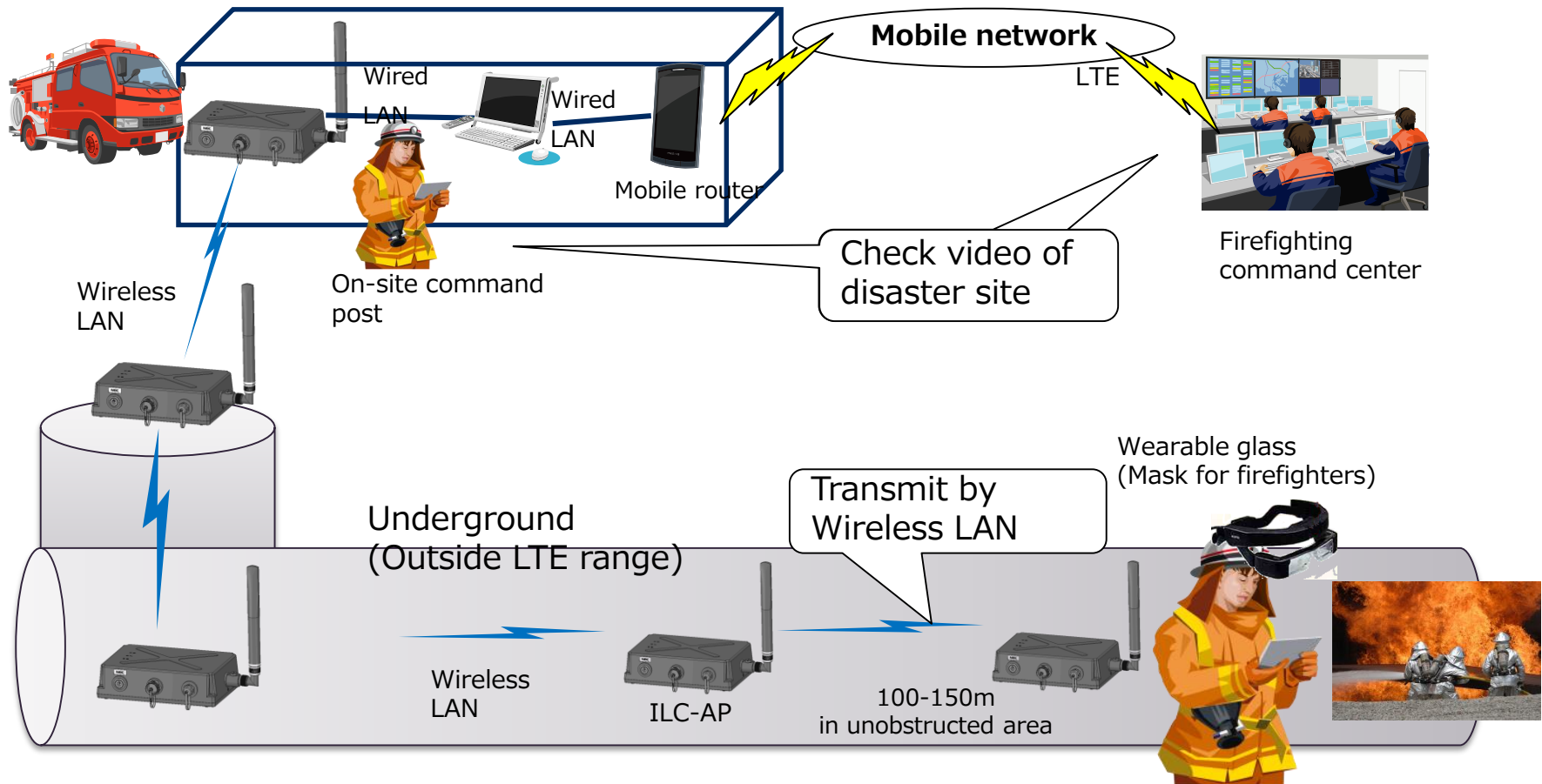

# Activities to support evacuees (Adopted by municipalities)

## Value

**Present situation:** Insufficient ability to assess the situation at evacuation centers hinders relief efforts.

**After introduction:** Information and requests can be collected from people in the vicinity, making it possible to provide support corresponding efficiently to the needs of victims.

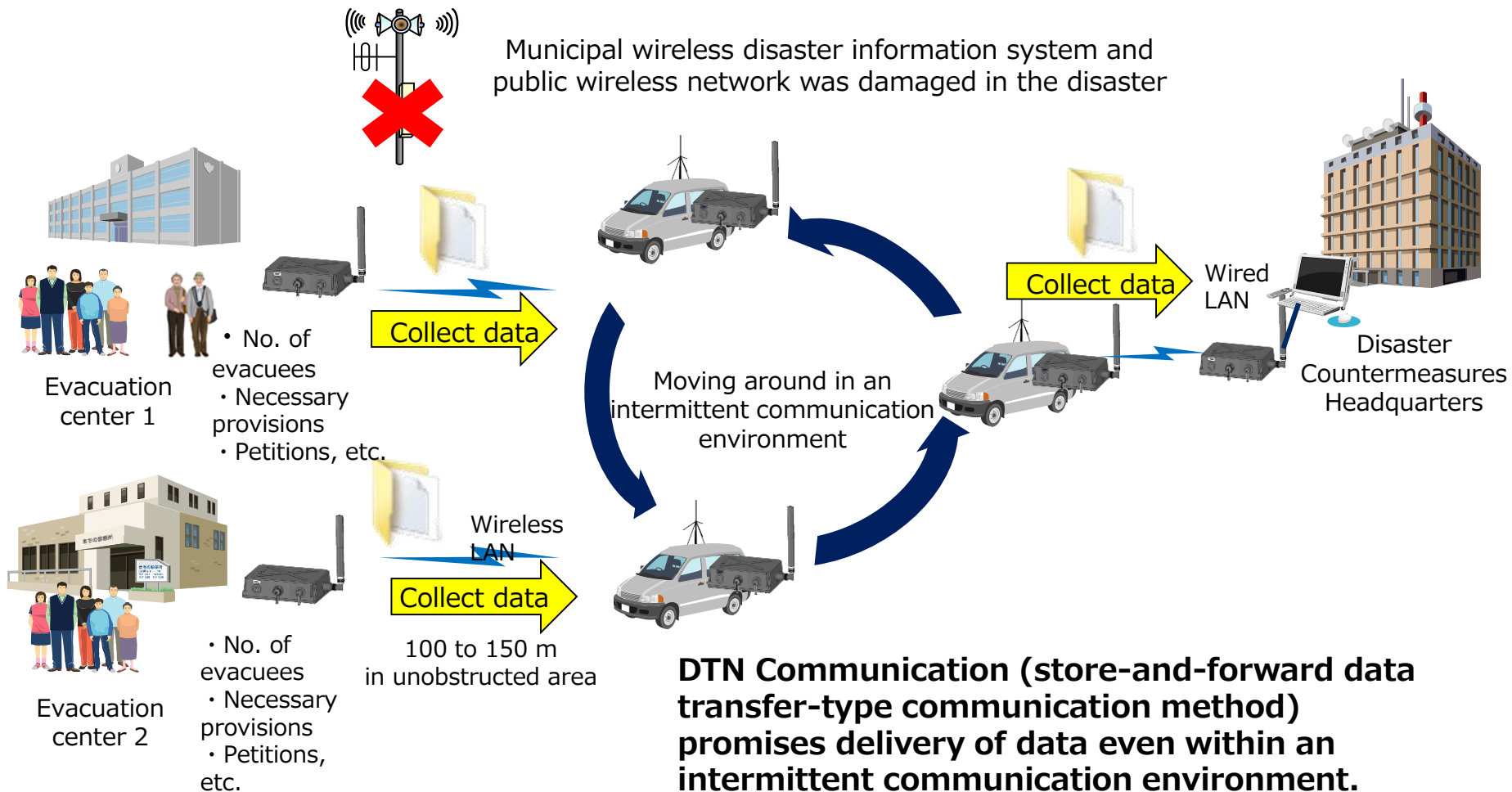

# Design diagram

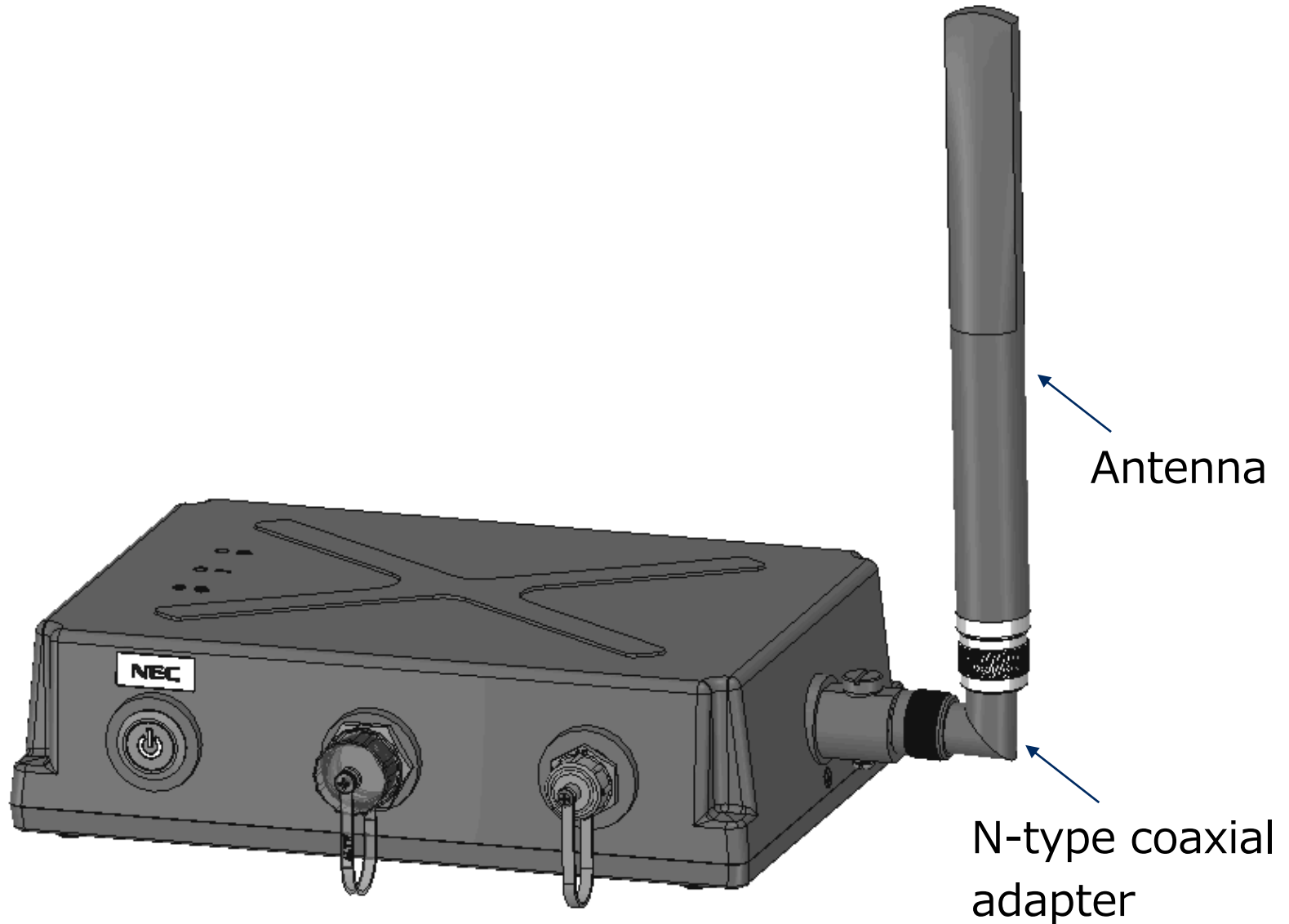

# Supported technology: MANET multi-hop routing control

## OLSR (Optimized Link-State Routing) protocol

- Because data is forwarded on top of a Layer-3 (IP layer) medium, the existing TCP/IP app can be used.

Condition of use: A fully connected network must be maintained

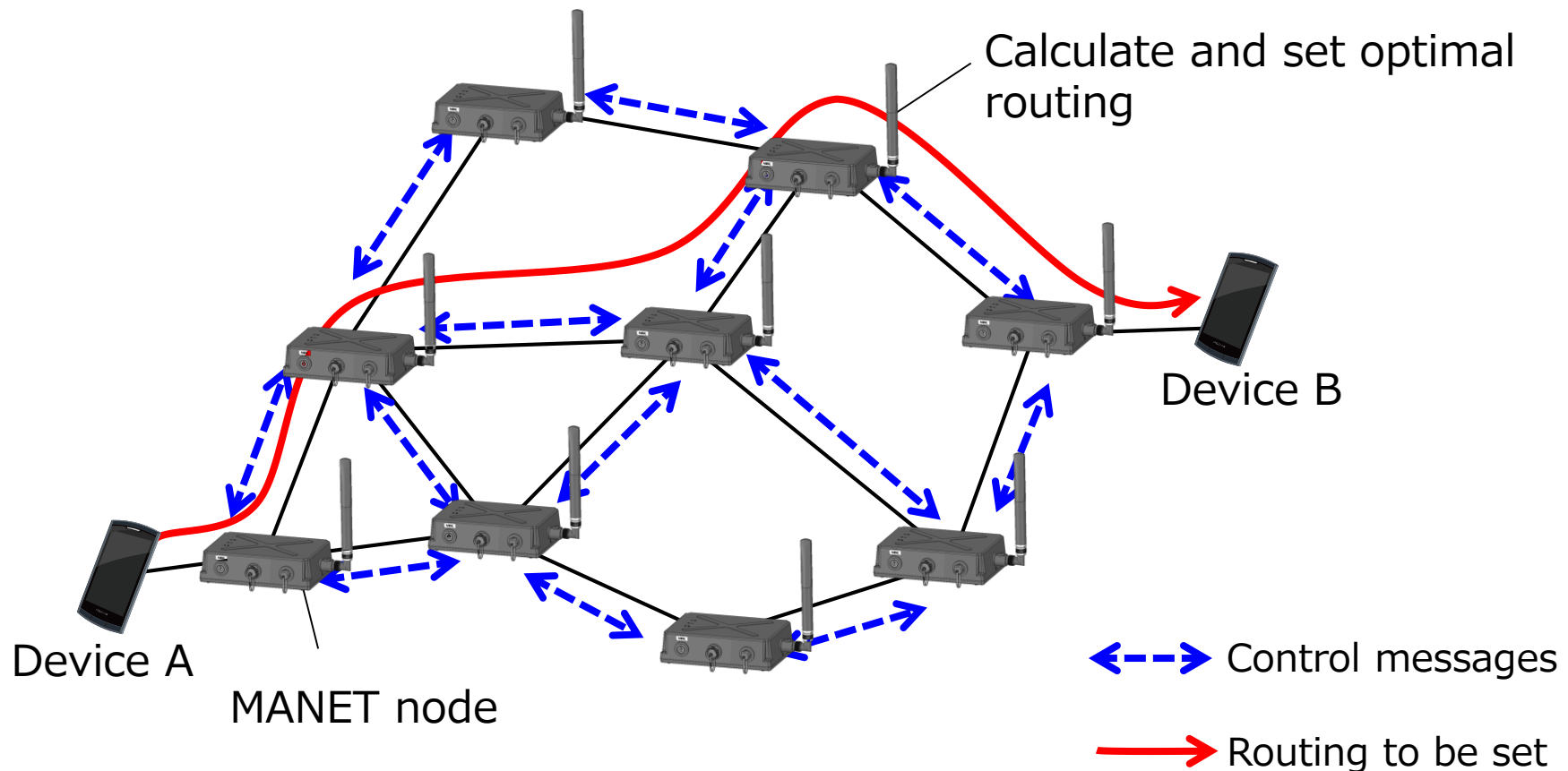

# Supported technology: DTN multi-hop forwarding

## Storage-type broadcast forwarding

- Received data is stored and forwarded by segment. Even if communication is interrupted, forwarding of data by segment restarts once a communication route is secured.

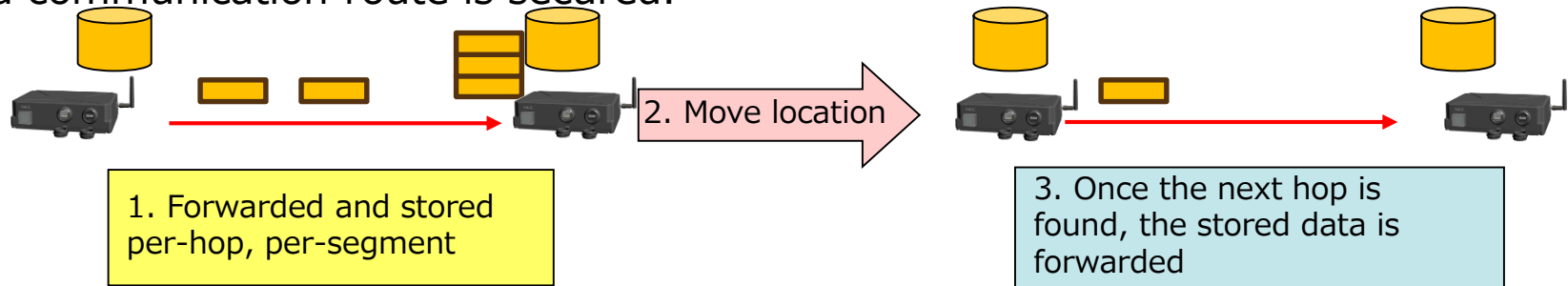

## Infection-type data transmission

- The data repeatedly misses the target and is simultaneously transmitted to the entire network

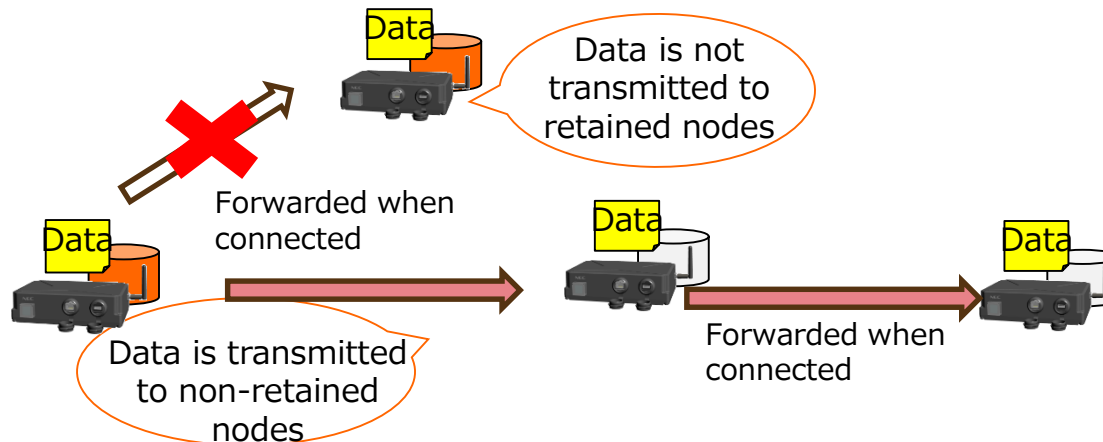

# Characteristics of infrastructure-less communication access points - Point 1

## The wireless LAN access point can be set up anywhere

- Each device can connect to the network using a smartphone or other mobile device as an access point.
  - The built-in battery allows use even without a power supply (8 hours continuous operation)
  - Portable (1160 g (device)/238x160x66mm)
  - Dustproof, waterproof (IP65 compliant)
  - RF extension cable (3 m) for connection between infrastructure-less communication access point and the antenna can be extended from the device.
- \* Prior to setup, the device must be pre-configured and the above-mentioned network must be prepared in advance.

## Scalable and portable network

- The system uses wireless LAN to successively forward (MANET) data from multiple infrastructure-less communication access points, giving rise to a scalable and portable network.
- The repeater setting etc. and the complicated setting are unnecessary.

## Wireless infrastructure-less communication access points are automatically detected, ensuring the selection of optimal communication routes. This allows access to highly effective networks with minimal data loss.

- Control packets are transmitted between the devices, providing up-to-the-minute information on the network's devices and communication status.
- Communication routes can be checked from the GUI of a smartphone or other mobile device.



# Characteristics of infrastructure-less communication access points - Point 2

## **The DTN function ensures data transmission even in unstable networks.**

- Because the received data is stored in the device before transmission, even if the connection is temporarily interrupted, the data can be sent once connection is restored.

- \* 1 If DTN is used, NEC-commissioned application development is needed.

- \* 2 The time period for storing data on the network can be set in advance.

When data is sent to a device that does not exist on the network, the data is erased and the system can be accorded the appropriate level of security.

## **The built-in GPS makes it possible to use another mobile device to check the whereabouts and track the movement of the device.**

- The built-in GPS makes it possible to access details regarding the circumstances of the device.

- Smartphones and other mobile devices can be used to check the whereabouts of the device.

- \* NEC-commissioned application development is needed.

## **The functions can be enhanced to meet requirements of use.**

- The device is equipped with function-enhancing memory, making it possible to add applications.

- Supports USBs (Mini Type B), and Ethernet ports.

(NEC-commissioned applications can be developed upon request)

# Product specifications

<b>Weight</b>	1160 g (device)
<b>Size</b>	238 x 160 x 66 mm
<b>LED</b>	Power supply LED/Indicator LED/Recharge LED
<b>Power supply (included)</b>	AC adaptor (12V/3A)
<b>Built-in battery</b>	Lithium ion 17400 mAh
<b>Operation time/power consumption</b>	Up to 8 hours (if the AC adaptor is not used to supply power)/6 W Conditions: Inter-device wireless LAN (MANET): 2.4 G continuous transmission Terminal connection (AP) wireless LAN: 5 G continuous transmission * Operational time may be shorter depending on factors such as temperature and changes to battery capacity due to repeated recharging or deterioration over time.
<b>Housing</b>	Dustproof and waterproof (IP65 compliant), excluding while recharging or when the connector is connected.
<b>Temp. range</b>	0-45°C
<b>Drop resistance</b>	Dropped on 4 sides (excluding sides with the protruding antenna and connectors) and 8 corners from a height of 75 cm *The fall resistance pertains to electrical functions only. Damage to the housing is outside the scope of the specifications.
<b>CPU</b>	IPQ8062
<b>Memory</b>	DDR3 1GB+eMMC 8GB+NOR 128Mb
<b>Wireless LAN</b>	Inter-device: IEEE802.11a/b/g/n 2.4G/5G (W52) AP: IEEE802.11a/b/g/n/ac 2.4G/5G (W52/W53/W56) Security: WPA2-PSK
<b>GPS</b>	GPS
<b>Exterior I/F</b>	USB Mini type B
	RJ45 (Ethernet connector) * 10/100/1000 Mbps
	N connector (for connecting the external antenna for inter-device communication)
<b>OS</b>	LINUX
<b>Certification</b>	Japan: TELEC/JATE only * Overseas: CE (R&TTE)/UL/FCC can be acquired upon request by the customer
<b>Accessories</b>	External antenna, L-type antenna connector (N-Type), mounting bracket, AC adapter
<b>Option</b>	Dustproof/waterproof extension antenna cable (3m)

# Environmental benefits of infrastructure-less communication access points

Among the eight risks of climate change indicated in the Intergovernmental Panel on Climate Change (IPCC) of the United Nations, the risks that can be mitigated by this solution are the following.

(See “The eight risks of climate change” on the following page)

(The numbering of the items below corresponds to the numbering of “the eight risks of climate change” on the following page.)

## 2. Damage caused by flooding in urban areas

When existing infrastructure is damaged and it becomes difficult to assess health hazards and other risks of the urban population, DTN communication can be used to send data even in intermittent communication environments, **making it possible to provide relief to victims.**

## 3. Breakdown of infrastructure and other societal functions due to extreme weather events

Each device is equipped with a wireless LAN access point, wireless LAN for the ad hoc feature of inter-device communication, and in-built battery, which makes it possible to simply place the ILC-AP to build a network even in areas without a power supply. Moreover, because the device has a DTN (Delay/Disruption-Tolerant Network) feature that allows received data to be stored in the device and sent when a communication route becomes available, data can be transmitted even under unstable and intermittent network connectivity. As a result, **even if a natural disaster causes a breakdown of infrastructure, this device can be used during disaster and recovery efforts, and contribute to the reduction of disaster risks.**

# The Eight Risks of Climate Change

Source: 5th Assessment Report of IPCC (2014)



**1. Damage caused by rising sea levels and storm surge in coastal areas**



**2. Damage caused by flooding in urban areas**



**3. Breakdown of infrastructure and other societal functions due to extreme weather events**



**4. Death and ill health caused by heat waves which particularly affect vulnerable groups in urban areas**



**5. Threat to food security caused by rising temperatures and drought**



**6. Loss of livelihood and income in rural areas due to insufficient water resources and reduced agricultural productivity**



**7. Loss of marine ecosystems that are vital to coastal water areas**



**8. Loss of services provided by terrestrial and inland water ecosystems**

 **Orchestrating** a brighter world

**NEC**