

STYLISH TOUCH SCREEN POS TERMINAL

# ***TWINPOS 5500U:***



**Reliability  
Meets Design**



# Attractive, robust and efficient POS terminal

TWINPOS5500Ui offers a next generation retail IT system with both reliable industry-standard hardware and stylish design to enhance any store's decor.



## Innovative product design

- Attractive curved back panels fits various kinds of stores' interior atmosphere
- Only POS product in the market with illumination lights
- Quick and easy store promotion by POP pocket at the customer display
- Side panels allow an accent color matching store interior

## Cutting edge technologies

- 2GHz enhanced CPU performance and 2GB main memory enables smooth POS operation, multimedia promotions, and various middle-wares as a core of retail IT solution
- Windows® Embedded for Point of Service supports Plug-n-Play for retail device peripherals, creates operator & customer interactions through empowering components, and provides low lifecycle cost for retailers and partners in the POS industry
- Conforms to OPOS specifications and provides a new POS application interface for .NET Framework 3.0
- One of industry's highest printing speed 240mm/s and print at 16 tones levels

·Background Printing Image



·Tone Printing Image



·Background Printing-Enlarged Image

·Tone Printing-Enlarged Image



·Partial Cut



·Full Cut

## Flexibility

- One of the world's smallest footprint among touchpanel POS terminals which allows it to fit various types of counter layouts
- Flexible hardware configuration and Plug-n-Play support for retail device peripherals are available
- Adjustable LCD tilt angle up to 90° for operator's best position

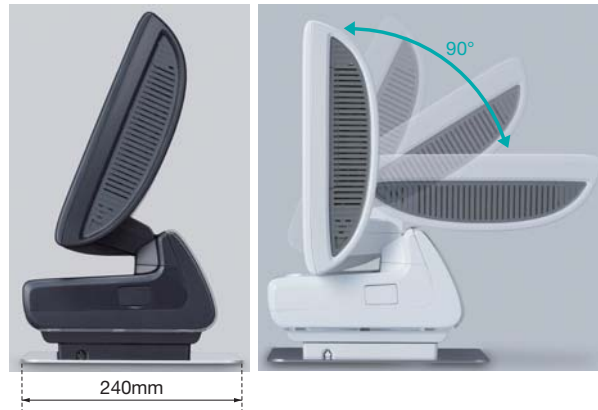

## Reliability

- Highly durable against temperature, water spills and dust, ideally suited for a demanding retail environment
- ECC (Error Correction Code) functions within memory modules automatically detects and corrects memory errors for more stable POS operations
- UPS (Uninterruptible Power System) battery is available as an option, which protects important data and hardware components by automatically shutting down with sudden power failures
- Power management function saves on operating cost by controlling the CPU clock, interfaces and displays when the POS operation is idle remove

## Sample hardware configurations

- POS Main Terminal
- Thermal Receipt Printer
- Illumination Light Kit

- POS Main Terminal
- Line Display
- Magnetic Strip Reader
- 84 Key POS Keyboard
- Thermal Receipt Printer
- Barcode Handheld Scanner

- POS Main Terminal
- Line Display
- 47 Key Vertical Keyboard
- Thermal Receipt Printer
- Barcode Handheld Scanner



● Specifications

Items	Specifications
CPU	Athlon™ 64 3100+ (2GHz)
Main Memory	2GB standard (2GB Max) with ECC function
Storage	2.5" SATA 80GB HDD (Single or mirrored)
OS	Windows® Embedded for Point of Service 1.1
Operator Display	15" XGA TFT with analog resistive touch panel
Customer Display	(option) Graphic FIP (fluorescence indicator panel) display (option) Graphic FIP display with adjustable pole
Interfaces	RS-232C x 2 ports (up to 4 ports with option) USB 2.0 x 8 ports (2 for maintenance use) Cash Drawer x 2 ports (+24VDC) Mic-in x 1 port, Audio-out x 1 port DVI-I output x 1 port
LAN	10/100BASE-T/TX Ethernet x 1 port
Receipt Printer	(option) 58mm width, 240mm/s thermal printer multi font / gradation print / cutting type control
POS Keyboard	(option) Built-in 47 key POS Keyboard (option) Built-in 47 key POS Keyboard with magnetic reader (option) Stand-alone 84 key POS Keyboard
Magnetic Reader	(option) Built-in reader ISO1/2/3
UPS	(option) Built-in battery system for safe shutdown
Other Options	(option) Color panel kit (option) Illumination light kit (option) POP panel for customer display (option) Barcode handheld scanner (option) 5 bills / 6coins cash drawer (option) COM extension unit (option) Touch panel face cover
Weight	Approx. 8.4kg (without options)
Power Supply	AC100-240V (+6%, -10%)
Power Consumption	Approx 43W (Max 120W, without options)

● Dimensions (Unit: mm)

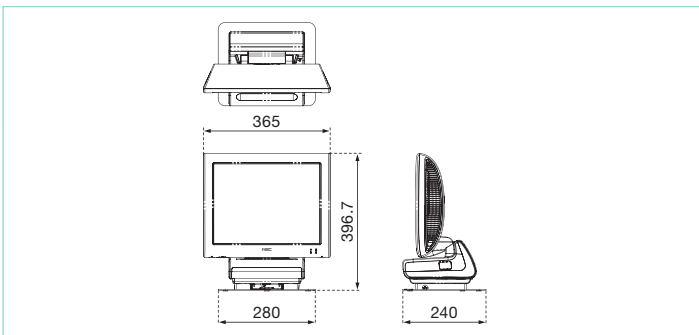

● Major options



47 key Vertical Keyboard



84 Key POS Keyboard



Customer Display with POP panel



ISO1/2/3 Magnetic Strip Reader



58mm 240mm/s Thermal Receipt Printer



Barcode Handheld Scanner

\*Microsoft Windows and Windows logo are trademarks or registered trademarks of Microsoft Corporation in the United States and other countries.

\*Athlon™ is a registered trademark of Advanced Micro Devices, Inc. See the notes in the relevant documents for details. The color of the products shown in this brochure may vary from the actual product due to the printing condition.

\*When exporting this product, take necessary procedures such as application for export permits from Japanese government, as stipulated in the Foreign Exchange and Foreign Trade Control Law.

Also, take required procedures for applicable U.S. Export Administration Regulations or other foreign government regulations.

⚠ Notes on Safety

Please read the documents attached to the products carefully for proper use.

Do not install in locations where high amounts of water, humidity, dust or oil smoke are present. Doing so may cause fire, breakdown or electric shock.

NEC Corporation

